

ROTARY AIR LOCKS

N.R. Murphy's Rotary Air Lock combines craftsmanship with trouble free efficient design to run all day long while continuously discharging waste. The Air Locks are used to provide an airtight seal on cyclones, dust collectors, storage bins, enclosed mechanical conveyors, etc. Featuring a heavy gauge all welded construction and made with a sturdy six blade rotor with replaceable full pocket, double wiper neoprene seals. Our standard design comes with a removable side plate for easy access to replaceable seals, and a T.E.F.C. motor. Special metals and/or seals are available for high temperatures, corrosiveness or product contamination. We also provide air locks that meet various safety codes, ask us for assistance!

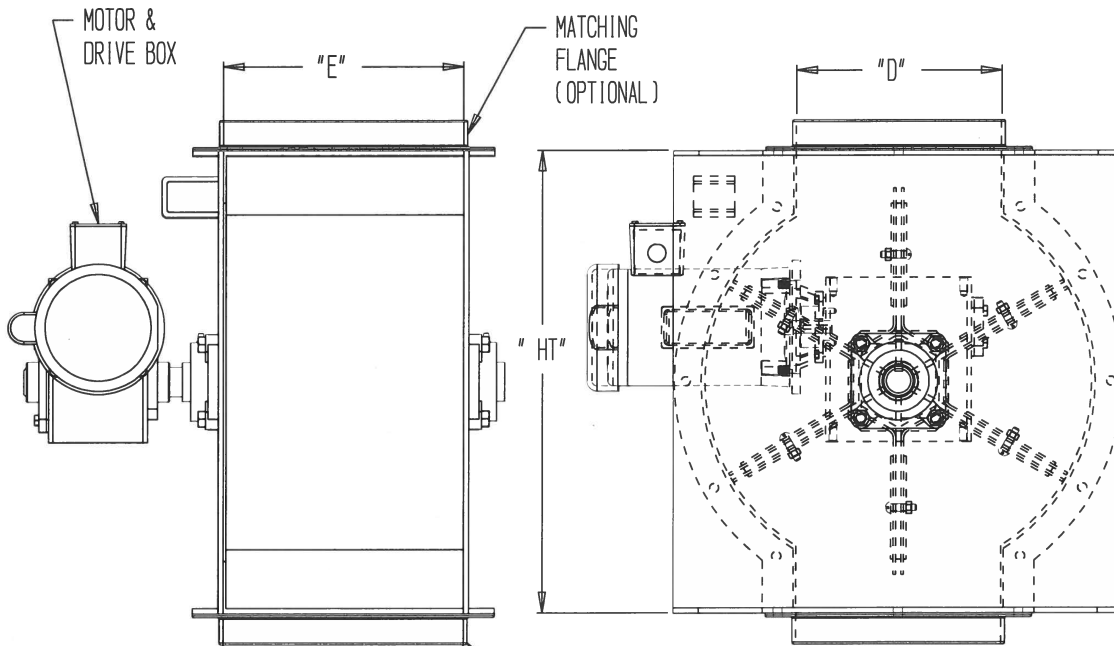

Model Number	Height			Inlet & Outlet Size		Motor H.P.	Cu. ft. per Min	Revolutions per minute	Approx. Total Weight
	A	B	C	D	E				
Size 1	22 1/2"	23 1/2"	24 1/2"	10"	11 3/4"	3/4	11.62	28.7	300
Size 2	34"	34"	31"	16"	17 3/4"	1 1/2"	36.47	19.3	775
Size 3	43 1/4"	44 1/2"	38 1/2"	20"	21 3/4"	2	57.91	14.3	1250